

REEFE DIGITAL
PRESSURE SWITCH

EXPLODED VIEW &
INSTRUCTION MANUAL



MODEL: EPS1 & EPS2

CODE: 24195 & 24881

GENERAL

Read carefully the instructions before installing this unit. Verify the technical characteristics of the motor in order to assure the compatibility with the device.

DESCRIPTION (diagram A)

SWITCHMATIC 1 is an electronic pressure switch with integrated digital manometer. It manages the start and stop of a single-phase pump up to 2.2kW (3 HP) (SW1-2). Cut-in and cut-out pressures are easily adjustable through the users control panel (See Startup (Diagram C)).

Wiring is analogous to the traditional electromechanical switch. It can operate as a differential pressure switch and as reverse pressure switch.

Unit SWITCHMATIC 2 in addition to all the above features of the basic SWITCH- MATIC 1 includes instantaneous reading of current drawn. This patented system controls and manages the overcurrent, dry-run operation and fast-cycling functions.

Unit SWITCHMATIC 2 in addition to all the features of individual assembly includes the option to be synchronized to another unit SWITCHMATIC 2, thereby, managing and protecting 2 pumps operating in cascade with alternated starting sequence. The SWITCHMATIC 3 unit is ideal for a control panel as it has a dry contact output.

CLASSIFICATION AND TYPE

According to IEC 60730-1 and EN 60730-1 this unit is a control sensor device, electronic, independent assembly, programming type A with action type 1B (microdisconnection). Operating value: I <20% I learned. Pollution degree 2 (clean environment). Rated impulse voltage: cat II / 2500V. Temperatures for ball test: enclosure (75) and PCB (125).

OPERATING CHARACTERISTICS (diagram C)

- Adjustable cut-in and cut-out pressures.
- Integrated digital pressure gauge with bar and psi indication.
- Inner pressure transmitter.
- Dry-run protection:
 - Through minimum adjusted height for basic SWITCHMATIC 1/3.
 - Through the instantaneous current consumption in case of SW2.
- Overcurrent protection.
- Overvoltage protection.
- ART Function (Automatic Reset Test). When the device has stopped the pump by the intervention of the dry-running protection system, the ART tries, with scheduled basis, to re-start the pump in order to

restore the water supply. See "ART. Automatic reset function". Must be activated in the step 6 of the ADVANCED MENU (Ar1).

- Fast cycling: when the hydropneumatic tank has lost too much air and, consequently, frequent start-stop cycles are produced this alarm is

activated and is delayed the start of the pump. Activated (rc2).

- Manual start push-button (ENTER).
- 3 operation modes: differential, reverse and synchronized.
- Control panel with 3-digit display, LED indicator lights and push-

buttons.

- Available settings:
 - Stand-by mode.
 - Minimum period between fast cycles.
 - Start and stop delay.
- Volt-free contact for monitoring the alarms is displayed on the screen (only version A).

TECHNICAL CHARACTERISTICS

- Rated motor power: 0,37-2,2 kW (SW1-SW2)
- Power supply: ~1 x 110-230 V (SW1-SW2)
- Electric outlet: ~1 x 48-230 Vac/Vdc (SW3)
- Nominal pressure: Dry contact (SW3)
1MPa/10bar (plus: 1,3MPa / 13bar)
- Frequency: 50/60Hz
- Max. current: 16 A, cos fi ≥ 0.6
- Protection degree: IP55
- Max water Temperature: 50°C
- Max environment Temperature: 60°C
- Cut-in range (start pressure): 0,5÷7 bar (version plus=11 bar)
- Cut-ot range (stop pressure): 1÷8 bar (version plus=12 bar)

HYDRAULIC INSTALLATION (diagram A)



SWITCHMATIC equipment must be threaded to a fitting G1/4" male at the pump's outlet.

Before connecting the SWITCHMATIC verify that the hydraulic system is properly installed, especially if the hydropneumatic tank is pressurized.

ELECTRIC CONNECTION (diagram B)



The electric connection must be performed by qualified personal in compliance with regulation of each country. Before doing manipulations inside the device, it must be disconnected from the electric supply. Wrong connection could spoil the electronic circuit.

The manufacturer declines all responsibility in damages caused by wrong connections.

When carrying out the electrical connection it is compulsory to use a differential switch of high sensitivity: I = 30 mA (class A o AC). It is compulsory to use a magnetothermic switch adapted at the motor load.

Check if power supply is between 115-230V (SW1-2).

If you have purchased the unit without cables follow diagram B:

- Use cables type H07RN-F 3G1 or 3G1,5 with section enough to the power installed.
- Do the pump connection U, V and Ⓢ (SW1-2) Ⓢ
- Do the power supply connection L1, N and .
- The earth conductor must be longer than the others. It will be the first one to be mounted during the assembly and the last one to be disconnected during the dismantling. **The earth conductors connections are compulsory!**
- (Only version A) The device has a volt-free contact for monitoring the alarms displayed in the screen originated by irregularities or problems of the system. For the connection see Diagram C.

CONTROL PANEL (diagram C)

The meanings of the different control panel elements are summarized on the following tables, where:

- O means lit LED light.
- ((O)) means slow-flashing.
- ((((O))) means fast-flashing.

DISPLAY	ACTION
OPERATION MODE	Instantaneous pressure or instantaneous current consumption is shown on screen
	The adjusted start pressure (blinking) is displayed on screen.
ADJUSTMENT MODE	The adjusted stop pressure (blinking) is displayed on screen. The adjusted rated current blinking (only SW2) is displayed on screen.
ALARM MODE	The alarm code is displayed
STAND-BY MODE	Are displayed 3 flashing dots
BASIC CONFIGURATION MODE	The sequence of basic configuration parameters is displayed.
ADVANCED CONFIGURATION MODE	The sequence of advanced configuration parameters are displayed.

LEDS	STATE	MEANING
bar	O	It indicates the instantaneous pressure in bar
	((O))	It indicates the instantaneous pressure in bar + pump operating (only SW1/SW3)
psi	O	It indicates the instantaneous pressure in psi
	((O))	It indicates the instantaneous pressure in psi + pump operating (only SW1/SW3)
A (only SW2)	O	It indicates the instantaneous current consumption in Ampere units
	((O))	Pump ON

- Max. differential (Pstop-Pstart) 7,5 bar (version plus=11,5 bar)
- Minimum differential (Pstop-Pstart) SW: 0,5 bar

- START
- O Is displayed the start pressure
 - ((O)) Adjusting start pressure
-
- O Displays the stop pressure
- Factory setting (start/stop) SW2 synchro: 1 bar
3/4 bar
 - Hydraulic inlet G1/4" Female - NPT 1/4" Fem.
 - Net weight (without cables) 0,3 kg

- STOP
-
- ((O)) Adjusting stop pressure
-
- O Ratified dry-running or overload alarms
-
-  ((O)) Dry-running alarm performing ART or overload alarm performing any of the 4 restore attempts
-
- (((O))) Fast-cycling alarm
-

P-BUTTON	TOUCH	ACTION
	Press	From state ON: unit OFF. From state OFF: the pump starts and keeps operating until reaching Pstop. From any configuration MENU: the parameter value is accepted.
	HOLD DOWN	From state ON: unit OFF. From state OFF: the pump starts and keeps operating until the push-button is released.
	Press	Pstart is displayed on the screen for 3 seconds.
	Hold for 3 sec	Pstart adjustment mode.
	Press	Pstop is displayed on the screen for 3 seconds.
	Hold for 3 sec	Pstop adjustment mode.
	Press	Instantaneous current consumption is displayed on the screen. If it is already displayed, then we switch to instantaneous pressure view.
	Hold for 3 sec	Rated current adjustment.

STARTUP (diagram C)

Before starting the device, please read the previous sections, especially "Hydraulic Installation" and "Electrical connection".

Follow next steps:

1. Only for type SW2 set the pump rated current intensity value.

- Press for 3 second duration.
- The current intensity value is displayed on screen, LED A lights up and display is flashing.
- By mean of and is adjusted the rated current reflected in the characteristics plate of the motor. See Note 1.
- Press for validation.

2. Start the device by pressing .

3. Set the cut-in (start) pressure:

- Press for 3 second duration.
- The start pressure value is displayed on screen, LED START lights up and display is flashing.
- By mean of and adjust the start pressure from 0,5 to 7 bar (+ version=11 bar).
- Press for validation.

4. Set the cut-out (stop) pressure:

- Press for 3 second duration.
- The stop pressure value is displayed on screen, LED STOP lights up and display is flashing.
- By mean of and adjust the stop pressure from 1 to 8 bar (+ version=12 bar).
- Press for validation.

5. The unit is ready to operate but more optional adjustments can be set through basic and advanced MENUS. See the next chapter.

Remark 1: it is important to introduce exactly the rated current specified on the nameplate of the pump.

BASIC MENU + (diagram C)

- Press simultaneously + for 5 second duration.
- By mean of or the values can be changed.
- Press for validation.
- The parameters sequence is:

it	TYPE	SYSTEM REACTION	FACTORY SETTING
1	BAR P	We can select the pressure units displayed between bar and psi.	bar
		Fast-cycling alarm: - rc0: alarm unabled.	
2	rc0 rc2	- rc1: activated, when hammering is detected it delays the start in order to protect the pump. - rc2: alarm is activated and the pump is stopped upon detection.	rc2
3	r.01 r.99	Only if fast-cycling alarm has been activated in the previous step (rc1&rc2), then selection of the maximum time period between 3 consecutive starts, which will be considered fast cycling (between 1 sec. and 99 sec.) can be chosen.	3 seconds

ADVANCED MENU + +

- Press simultaneously + + for 5 second duration
- By mean of or the values can be changed.
- Press for validation.
- The parameters sequence is:

it	TYPE	SYSTEM REACTION	FACTORY SETTING
1	nc no	Select the operation MODE as a conventional pressure switch (nc = normally closed) or reverse (no = normally open). *see Note 3	nc
2	E00 E01/02	(Only Switchmatic2). Select the operation mode Individual (E00) or Master/Slave (E01/E02) in case of be assembled in groups of two pumps.	E00
2.1	d.05 d.1	(Only Switchmatic2). Sets the minimum gap between Pstart 1 and Pstart 2 and/or Pstop 1 and Pstop 2.	d.05
3	ct0 ct9	Sets a time delay between 0 and 9 seconds to the start (is not available in synchronized operation mode).	ct0
4	dt0 dt9	Sets a time delay between 0 and 9 seconds to the stop.	dt0
5	Ar0 Ar1	Activation of the automatic restore system ART (Ar1) o disable (Ar0).	Ar0
6	P0.0 Pxx	It allows setting a minimum operating pressure under which the device would determine dry-running operation. It is very usefull in the basic model SWITCHMATIC where there is no reading of current intensity drawn. See Note 2.	0 bar 0 psi
6.1	t05 t99	Set the time period between 5 and 99 seconds below the minimum operating pressure that will be considered a dry-running operation.	20"
7	c10 c30	It allows setting a % of nominal current above which the device will activate the overcurrent protection.	c20
8	rS0 rS1	If we change rS0 to rS1 and push ENTER default values are restored.	rS0

Note 2:

Basic SWITCHMATIC 1/3 can only detect dry-running operation through the minimum pressure. This means that the installer must determine the water column of the installation, the start pressure of the pump and place the minimum pressure below the start pressure.

It can also occur that pumping system is running out of its curve so that the pump is unable to provide the minimum pressure because the flow requirement is excessive. In this case SWITCHMATIC 1/3 would activate a false dry-running alarm.

If these concepts are not clear, it is preferable not configure this protection or install the SWITCHMATIC 2 with accurate and easy setting of dry-run detection.

Note 3:

By choosing "no" (normally open) it will operate as an auxiliary pressure control element in the suction of the pump. It will restart when the suction pressure reaches the configured PStart.

Example:

- PStop: **0,9 bar**
- PStart: **1,2 bar**

4 Sb0 Sb1 Stand-by mode activated (Sb1), for low power consumption, or disabled (Sb0). Sb0

SYNCHRONISATION (ONLY FOR SWITCHMATIC 2)

SWITCHMATIC 2 can be synchronized to another unit SWITCHMATIC 2 managing and protecting 2 pumps operating in cascade with alternated starting sequence. Next steps must be followed:

- GO TO ADVANCED MENU: + + for 5 second duration.
 - In **step 2**: select E01 in a unit (this one will be the master) and select E02 in the other unit (this one will be the slave).
 - In **step 3**: select **identical** parameters of gap between pressures d.XX. This is the difference between the starting pressure of main and auxiliary pumps, it is also the difference between stop pressures of both pumps.

Differential (dX.X) = Pstop - Pstart ≥ 1 bar
Gap (d.XX) = Pstop1 - Pstop2 = Pstart1 - Pstart2

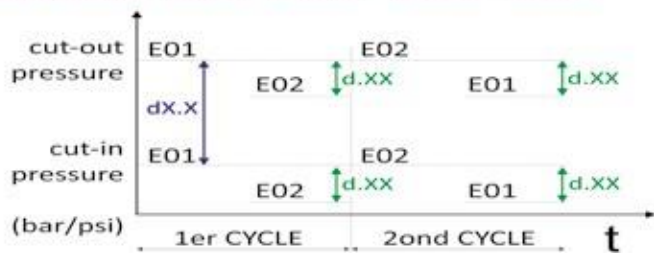

- Press repeatedly until the ADVANCED MENU is exited.
- SET **identical** cut-in and cut-out pressures in both units.
To optimize the synchronization, the minimum difference between the start and stop pressures must be at least 1 bar.
- Press in order to disable the units. Is displayed "OFF".
- Press again in both units in order to activate the synchronization.

Note 4: after 10 cycles the unit configured E01 will display pressure and the unit configured E02 will display current in Amps.

PRESSURE SENSOR CALIBRATION

In case of wrong selection of the pressure sensor, it can be adjusted again. For the pressure sensor calibration, it is necessary to have a pressure gauge in the installation. Proceed following the next steps:

ZERO REGULATION

- Open the taps living the hydraulic net without pressure.
- Press simultaneously the buttons and until the display show 0.0 flashing.
- Press to validate.

FULL SCALE

- Start the pump until cut-out of the pressure switch.
- Press simultaneously the buttons and till the display flashes with a figure.
- Adjust the pressure with the arrows push-buttons to get the pressure desired.
- Press to validate.

Note 5: pressure sensor calibration should not be a normal event. If it is frequently repeated contact the technical service.

WARNINGS AND ALARMS

COD.		DESCRIPTION	SYSTEM REACTION
		DRY-RUNNING	When a dry-run operation is detected, the pump is automatically stopped. By means of ENTER the normal operation can be manually restored.
A01		(Only for SWITCHMATIC 2) ((O))	is enabled, a first attempt at 5 minutes and then an attempt every 30 minutes for 24 hours is performed in order to restore the normal operation. This alarm can also be reset manually with the ENTER push-button. If the alarm persists after 24 h we find a definitive alarm.
A11		(BY MINIMUM PRESSURE)	Is displayed during normal operation if the pressure is below the minimum pressure (Px.x) - previously set - during a period (txx) - also previously set - in the ADVANCED MENU. If at any time the pressure exceeds the minimum pressure, the operation is restored automatically, and the alarm is cleared. Normal operation can also be restored manually by pressing ENTER.
A02		OVERLOAD (Only SW2) ((O))	Overcurrent alarm is activated when the nominal pump current is exceeded. 4 automatic reset attempts prior to the final alarm is performed. During the attempts, display will show current. Normal operation can also be restored manually by pressing ENTER.
A04		FAST CYCLING (Hammering)	This alarm can be disabled or activated in the BASIC MENU. The alarm is activated when 3 consecutive cycles occur in a range lower than the set time (between cycle and cycle). If it has been activated rc1, this alarm does not stop the normal operation but adds 5 seconds to the start delay in order to protect the electric pump. If it has been activated rc2, the pump is stopped. To RESET the normal operation press ENTER.
A05		DAMAGED PRESSURE SURE TRANS-MITTER	CONTACT WITH YOUR SUPPLIER.

DIAGRAM A

INDIVIDUAL

SWITCHMATIC 1/2

SWITCHMATIC 3

Set pressure tank to 0.5bar below start pressure

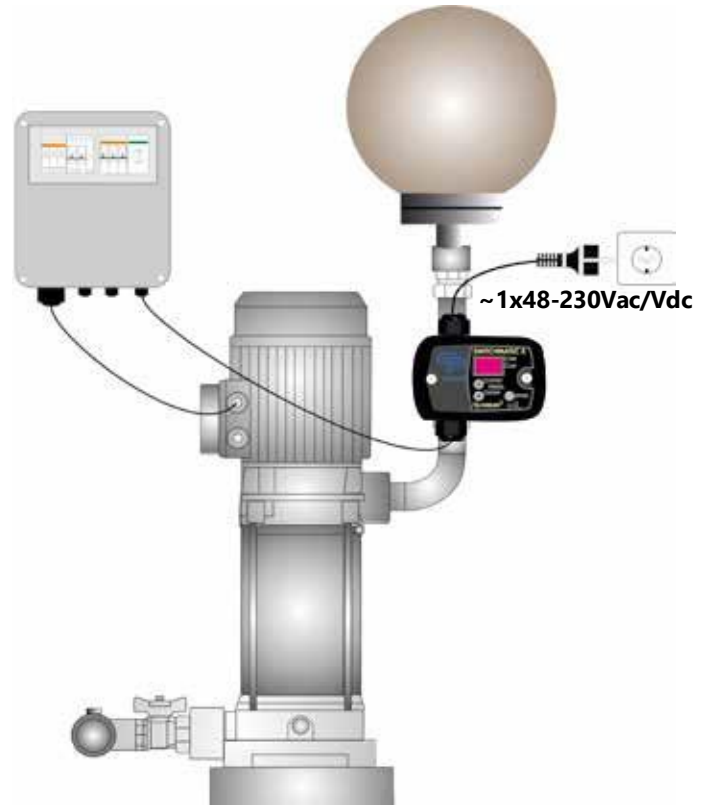
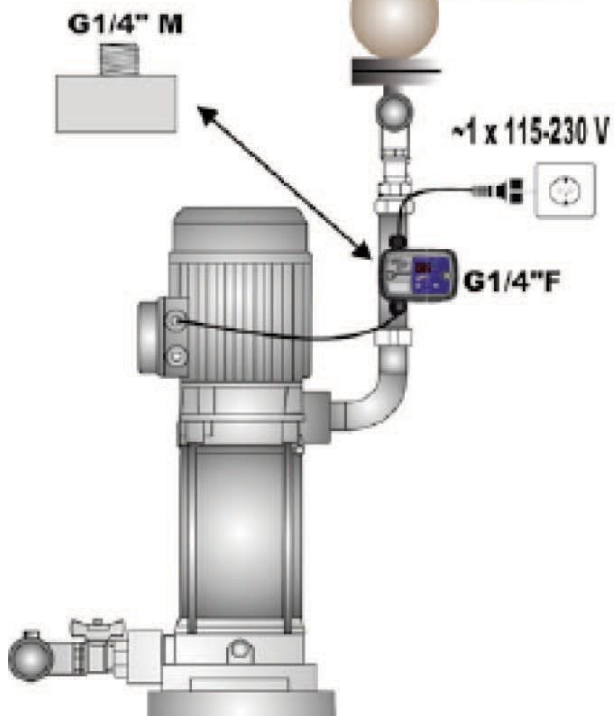

GROUPAL (ONLY SW2)

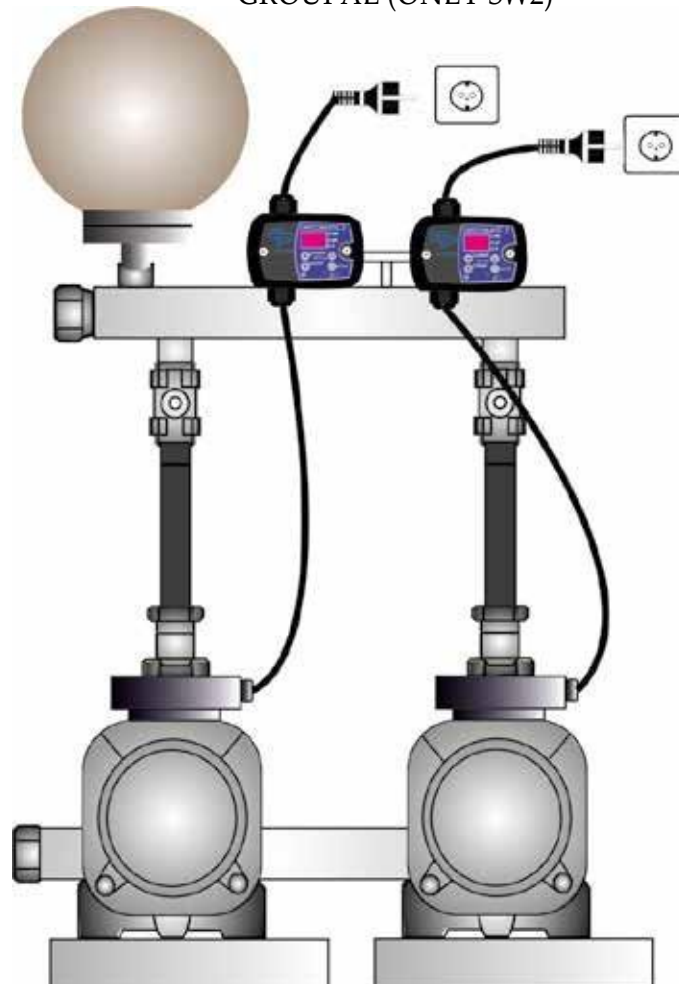

DIAGRAM C

SWITCHMATIC 1

SWITCHMATIC 2



DIMESIONS

SWITCHMATIC 1/2

SWITCHMATIC 2

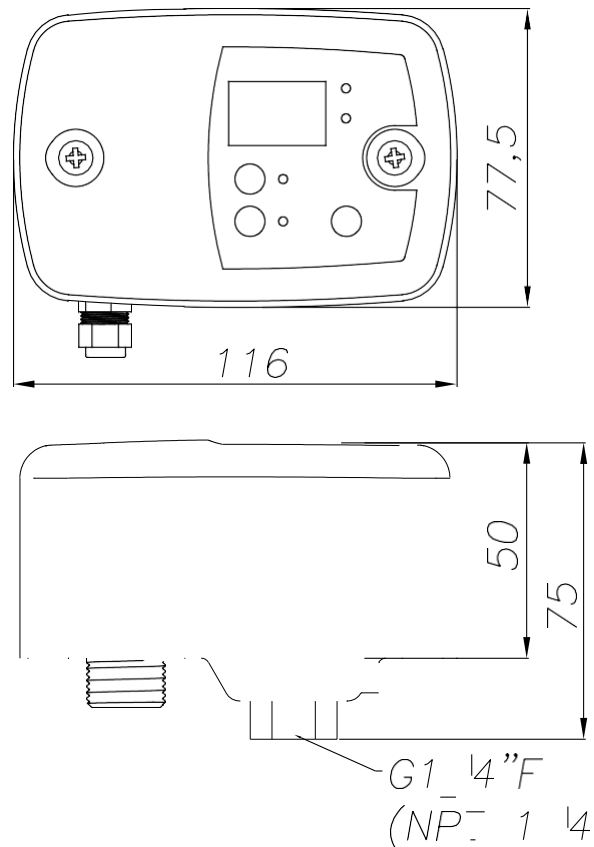
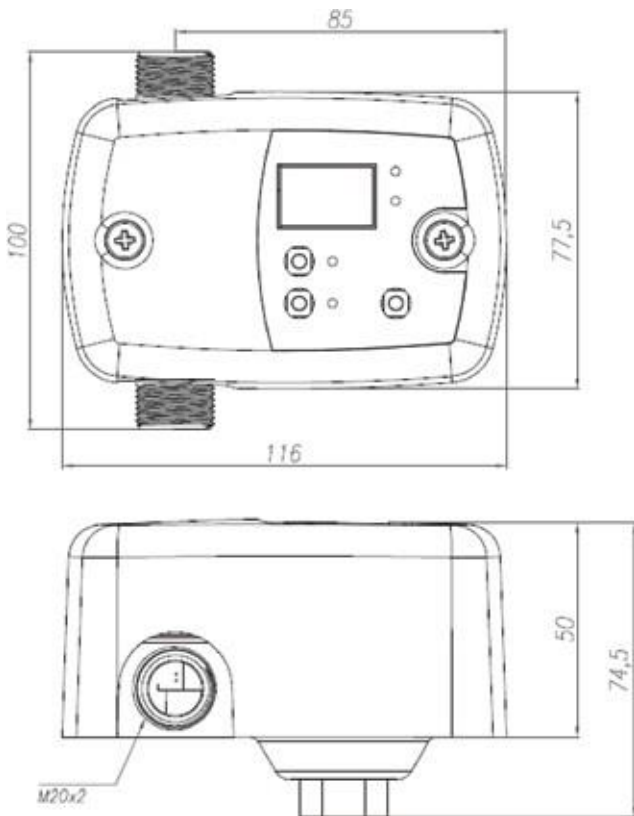

V11_042019